

## Technical Data DM-qode

process	injection molding, other on request
plastic materials	PS, PP, PC, ABS, PA, POM, COP other polymers on request
forming machine type	machine independent
marking trigger	self-triggering using internal temperature sensors
mold temperature	up to 80 °C (higher on later version)
cavity pressure	up to 2000 bar
minimal cycle time	3s (including 100 ms marking)
DynamicMold® Controller	125 mm x 80 mm x 57 mm
DynamicMold® LinQ	180 mm x 120 mm x 61 mm
DynamicMold® Insert	8 mm diameter x 20 mm
Connectivity	OPC UA, LAN, LTE-M, DM-Cloud

[version Oct 2023]

**matriq**

matriq AG  
Lerchenfeldstrasse 3  
9014 St. Gallen  
Switzerland



matriq.ch  
contact@matriq.ch



# A New Era In Plastic Part Marking

DM-qode brings individual marking  
into your mold.

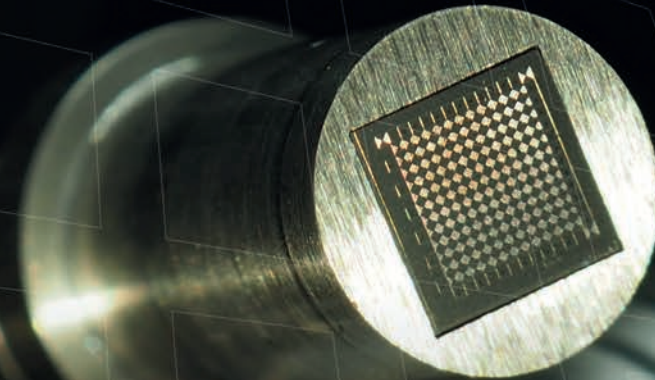

**matriq**

# In-cavity Plastics Marking

Better, faster, and more sustainable: Our game-changing **DynamicMold®** technology ensures an uninterrupted production of plastic parts while marking them with a unique DataMatrix code (DM-qode) directly during injection molding, blow molding, or thermoforming.

## DM-qode benefits:

- individual: serialize products for identification and traceability
- fast: no delay to cycle time
- automatic: self-changing per cycle
- sustainable: production and marking done in one process
- cost-effective: no additional equipment required

Marking hardware and cloud system.

1. DynamicMold® **Insert(s)**
2. DynamicMold® **Controller**
3. DynamicMold® **LinQ** with tablet and LTE-M module
4. DynamicMold® **Cloud**

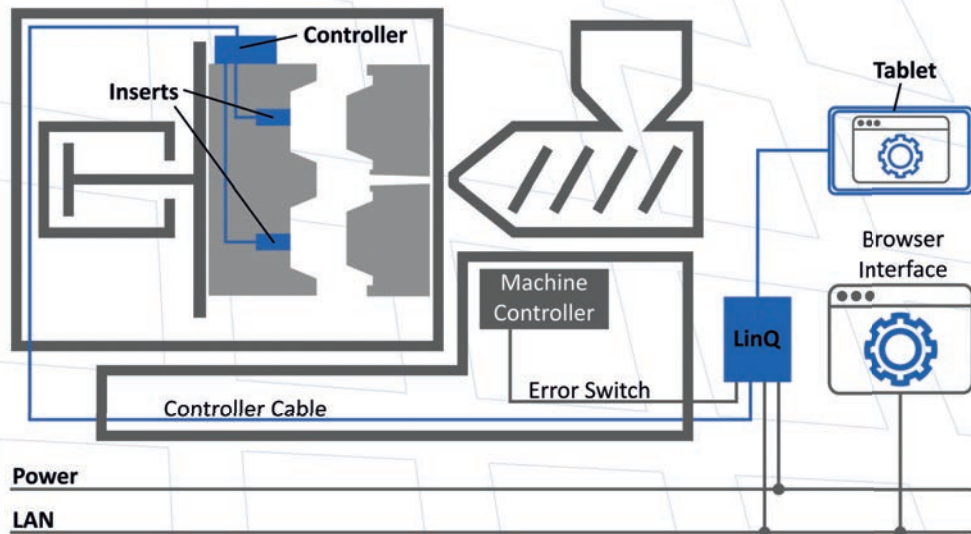

# The New DM-qode

Unique, secure and fully traceable: Our new DM-qode solution marks polymers with a unique camera-read DataMatrix code during the shaping or reshaping processes. Use our code to link to:

- process and material data
- manufacturing date
- serial number
- product information



## Simple Implementation

The mold insert is delivered ready to be mounted. It is installed into the prepared opening of each mold cavity.

The DynamicMold® Controller is fixed onto the mold tool and drives several inserts.



## Easy Readability

The ISO-conform DataMatrix code reveals as a contrast pattern of glossy and opaque pixels embossed on the surface of the plastic part. It can be read by industrial code-reader cameras.

