



Marking Solution

DM-qode Gen1

Operating Manual

## Contact Data

matriq AG  
Lerchenfeldstrasse 3  
CH - 9014 St. Gallen

Internet: matriq.ch  
E-Mail: [contact@matriq.ch](mailto:contact@matriq.ch)  
Phone: +41 71 571 48 50

## Product Details

Type: DM-qode Gen1  
Classifications : DynamicMold® Insert  
DMQ-01-xxxx-xxxx-x (x: 0...9, a...z), z.B. DMQ-01-12xx-db01-m  
DynamicMold® Controller  
DMC-02-qxx-axx (x: 0...9, a...z), z.B. DMC-02-q2x-axx  
DynamicMold® LinQ  
DML-02-xxx-xxx (x: 0...9, a...z), z.B. DML-02-xxx-xch  
Tablet  
TAB-01-xx-xx (x: 0...9, a...z), z.B. TAB-01-07-xx  
Controller Cable  
CAB-01-xx-xx (x: 0...9, a...z), z.B. CAB-01-05-xx

## Document

Name: matriq\_DM-qodeGen1\_BA1\_Rev03\_EN  
Version: Rev03  
Date: 03/2025

The original instructions were written in German. In the case of any discrepancies, the German version prevails.



## Table of Contents

<b>1</b>	User Information .....	3
1.1	About this operating manual.....	3
1.1.1	Keeping and passing on the operating manual .....	3
1.1.2	Target group .....	3
1.1.3	Validity.....	3
1.1.4	Structure.....	4
1.1.5	Presentation .....	4
1.1.6	Warnings .....	4
1.1.7	Symbols used in this operating manual.....	5
1.2	Definition of Terms.....	5
1.3	Copyrights .....	5
<b>2</b>	Safety.....	6
2.1	Hazards and Risks .....	6
2.1.1	Electricity.....	6
2.1.2	Elevated Temperatures .....	6
2.2	Intended Use .....	7
2.3	Qualifications.....	8
2.3.1	Trained personnel .....	8
2.3.2	Competent personnel.....	8
2.3.3	Authorized personnel.....	8
2.4	Operating Requirements .....	8
<b>3</b>	System Description.....	9
3.1	Overview .....	10
3.2	Interfaces.....	10
3.3	Status Display .....	11
3.4	Error Contact .....	11
3.5	Symbols .....	12
<b>4</b>	Transport and Storage.....	13
4.1	Transport.....	13
4.2	Storage .....	13
<b>5</b>	Installation.....	14
5.1	General Information .....	14
5.2	Wiring Diagram.....	14
5.3	DynamicMold® Insert .....	15
5.3.1	Installing a DynamicMold® Insert.....	15
5.4	DynamicMold® Controller .....	16
5.4.1	Installing and connecting the DynamicMold® Controller.....	16
5.5	Controller Cable.....	17
5.5.1	Installing and Plugging in the Controller Cable .....	17
5.6	DynamicMold® LinQ .....	18
5.6.1	Installation Conditions.....	18
5.6.2	Connecting the DynamicMold® LinQ.....	19
5.6.3	Connecting the Tablet .....	20
<b>6</b>	Operation .....	21
6.1	Using the Software* .....	21
6.1.1	Tablet-Mode.....	21

---

6.1.2	Network-Mode .....	21
<b>7</b>	<b>Maintenance .....</b>	<b>22</b>
7.1	Cleaning the DynamicMold® Insert .....	22
7.2	Cleaning Tablet .....	22
<b>8</b>	<b>Dismantling and Disposal .....</b>	<b>23</b>
8.1	Dismantling .....	23
8.2	Disposal .....	23
<b>9</b>	<b>Technical Data .....</b>	<b>24</b>
<b>10</b>	<b>Attachment.....</b>	<b>26</b>
10.1	EC-Declaration of Conformity.....	26

# 1 User Information

## 1.1 About this operating manual

This product from manufacturer matriq AG (“matriq”) is complete and safe for you to use. This operating manual shows you:

- ▶ How to set up and install the product
- ▶ How to connect it to electricity
- ▶ How to start up and operate the product
- ▶ How to detect errors
- ▶ How to dismantle the product
- ▶ How to dispose of the product

Read these instructions thoroughly and completely before you start working with the product. We at matriq are committed to providing you with all the information you need to operate our products completely and safely. If you still have questions this operating manual does not answer, please contact us. This operating manual shows the DM-qode Gen1 marking solution’s components in generalized form. Specific drawings are provided for you in the download section of [matriq.ch/support](https://matriq.ch/support).

### 1.1.1 Keeping and passing on the operating manual

Keep this operating manual and any other product-related documentation for this product handy and close to it.

### 1.1.2 Target group

This operating manual is intended for trained specialists familiar with the handling of injection molds and with electrical and electronic assemblies. A trained specialist is anybody whose technical training, knowledge, and experience, along with knowledge of the relevant rules and regulations, enables him to assess the assigned job and recognize its potential hazards.

### 1.1.3 Validity

This operating manual becomes valid when the trained specialist operating the matriq product receives it. The revision number and release date of this operating manual are included in the footer. This operating manual can be changed at any time and no reason for the change needs to be given.

#### NOTE



The current revised edition of this operating manual replaces all previous versions.

### 1.1.4 Structure

This operating manual is divided into chapters. They are ordered to help you activate the product quickly and safely.

### 1.1.5 Presentation

Step 1

↳ Result from the step

⑥ = Graphic reference

### 1.1.6 Warnings

You will find warnings before any instruction in the manual where exposure to the risk of personal injury or damage to property exists. Comply with all described safety measures.

Warnings are structured as follows:

#### **DANGER!**



##### **SOURCE AND IMPACT**

Explanation where necessary.

▶ How to avoid or prevent it.

In an emergency...

- ▶ Warning triangle: Draws your attention to the danger.
- ▶ Signal word: Indicates the hazard's severity.
- ▶ Source: Designates the hazard type or its source.
- ▶ Impact: Describes the impact of any failure to comply
- ▶ Avoidance: Indicates how to avoid or prevent it.
- ▶ In an emergency: Indicates what you should do should the described hazard occur.

#### **DANGER!**



Indicates an imminent, major hazard certain to result in serious injury or even death if the hazard is not avoided.

#### **WARNING!**



Indicates a potential hazard certain that may result in serious injury or even death if the hazard is not avoided.

#### **CAUTION!**



Indicates a potentially hazardous situation certain which, if not avoided, may result in moderate or minor bodily injury and property damage.

#### **NOTE**



Paragraphs with this symbol provide important information about the product and how to handle it.

### 1.1.7 Symbols used in this operating manual



General warning triangle



Dangerous electrical voltage



Hot surface warning

## 1.2 Definition of Terms

Term	Description
DM-qode Gen1	Complete in-cavity marking solution consisting of hardware components and software
DynamicMold® Insert	Insert to be installed in the mold incl. the cable to the DynamicMold® Controller
DynamicMold® Controller	Control unit mounted on the mold
DynamicMold® LinQ	Central I/O system for data management and energy supply
Controller Cable	Cables connecting the DynamicMold® Controller to the DynamicMold® LinQ
DynamicMold® Software	Software for controlling and monitoring the DM-qode Gen1 marking solution
Tablet	Tablet PC as user interface for system configuration

## 1.3 Copyrights

This operating manual contains information protected by copyright. No content or excerpts from this manual may be copied or reproduced in any other form without the prior permission of matriq, the product manufacturer.

# 2 Safety

This chapter summarizes all the information you should know in order to operate the DM-qode Gen1 marking solution safely.

## 2.1 Hazards and Risks

The marking solution is state-of-the-art and constructed in compliance with recognized safety rules. Improper use may pose a danger to persons and property. Disregarding occupational safety rules may result in damage. This chapter describes the possible hazards the marking solution can cause.

The DM-qode Gen1 marking insert operates in injection molding machines where temperatures greater than 100°C and pressures of up to 2,000 bar can occur. Therefore, follow the instructions for operating the injection molding machine you will be using and comply with all system's safety instructions.

### 2.1.1 Electricity

It must be generally assumed that all system components and their parts are live.

---

**⚠ WARNING!****DANGER OF ELECTRIC SHOCK!**

Never open system component housings and do not handle or try to change connection lines.

- ▶ Take any damaged cables and connectors out of service and have them replaced.
  - ▶ Keep the system components in the environmental conditions indicated for them.
- 

### 2.1.2 Elevated Temperatures

During normal operation, the DynamicMold® Insert in the DM-qode Gen1 marking solution is installed in the mold and poses no danger to persons. Any operation of the system outside the mold, including for testing purposes, is prohibited and considered improper use (see 2 **Fehler! Ungültiger Eigenverweis auf Textmarke.**).

---

**⚠ CAUTION!****BURN HAZARD!**

The DynamicMold® Insert can reach an elevated temperature.

- ▶ Do not touch any part of the DynamicMold® Insert and let all system parts cool down before doing any work with them.
-

## 2.2 Intended Use

The DM-qode Gen1 is intended exclusively as an in-cavity marking solution for injection mold applications. The DynamicMold® insert should only be used as a mold for injection molding machines. The marking solution is used as an additional component to generate digital markings in molding or shaping and may only be used for this purpose. Only operate it in industrial areas and with system components manufactured by matriq.

### You are using the marking solution as intended:

- ▶ When you strictly follow the instructions and sequence of actions in this operating manual and take no unauthorized action that puts your safety at risk and endangers the solution's own functional reliability.
- ▶ When you take all the safety precautions this operating manual prescribes.
- ▶ When you only use components specified for use in the matriq marking solution. This does not apply to use of an RJ45 network cable or a power cable.

### You are misusing the marking solution:

- ▶ If you are not following the instructions in this operating manual and the information it provides about assembly, maintenance and disposal.
- ▶ If it is used under conditions and specifications other than what the manufacturer has specified in its operation and installation instructions, technical documentation, data sheets, and other specific guidance.
- ▶ If it is used outdoors.
- ▶ If it is installed on inappropriate systems.
- ▶ If any of the solution's components are converted or modified.
- ▶ If the product or any of its components are either damaged or corroded. This also applies to any seals or cables used with the solution.
- ▶ If the product is used in potentially explosive atmospheres. Never use the solution in such environments because it has no protection against them.
- ▶ If it is operated in a condition where live parts are exposed.
- ▶ If it is operated in an enclosure with inadequately sealed inlets.

matriq warrants and guarantees only the solution's conformity to its own published specifications. If it is used in a manner not described in this operating manual, the solution will be compromised and any claim under the warranty will not be accepted.

## 2.3 Qualifications

This operating manual refers in several chapters to the qualifications of the people who may be eventually involved in installing, operating and maintaining it. There are three types of people qualified to work with the solution:

- Trained personnel
- Competent personnel
- Authorized personnel

The product is not intended for use by anybody (including children) with a physical or mental disability, or a lack of experience or knowledge about it, unless they are supervised or have been instructed about its use by someone responsible for their safety.

### 2.3.1 Trained personnel

Trained personnel are individuals who, based on their technical training, possess the necessary knowledge in the relevant field. These include, for example, skilled workers such as fitters or toolmakers who are able to assemble and install the unit under the supervision of competent or authorized personnel. They must have experience in handling the product.

### 2.3.2 Competent personnel

Competent personnel are individuals who, due to their professional training, possess sufficient knowledge in the required field and are familiar with the occupational health and safety regulations of the country in which the system is operated, with site-specific accident prevention regulations, applicable directives, and generally accepted rules of technology. Such personnel must be able to assess the results of their work safely and must be familiar with the contents of this operating manual.

### 2.3.3 Authorized personnel

Authorized personnel are individuals who have either been assigned to a specific task based on statutory requirements or have been specifically authorized by matriq to perform certain activities.

## 2.4 Operating Requirements

Exposure to the risk of accidents will be reduced if anybody operating the solution:

- Complies with statutory regulations on preventing accidents, occupational safety and environmental protection.
- Keeps the marking solution and injection molding system clean

Responsibilities for the solution's operation are required to be clearly defined. Whoever will be operating the solution should accordingly receive regular instruction in how to use it. Compliance with occupational health and safety regulations in the country where the solution will be operating is likewise required. Accordingly, a risk assessment should be carried out and written instructions drawn up for whoever will be operating the solution.

There are always potential hazards associated with work and maintenance on electrical power sources. Anyone not familiar with such equipment and installations may cause harm to themselves and others.

Operators of equipment containing electrical devices have to be instructed by the operating company before starting work. This instruction has to cover potential hazards, the necessary safety measures, and all applicable safety regulations.

# 3 System Description

The DM-qode Gen1 is an in-cavity marking solution for plastic products produced by injection molding, blow molding or other plastic manufacturing processes.

One or more DynamicMold® Inserts **1** are mounted in the mold cavity and connected to the DynamicMold® Controller **2**, which is itself mounted on the outside of the mold and can control up to four inserts. Due to the high thermal and mechanical loads within the mold, the insert is subject to wear and must therefore be considered a wear part with a limited lifetime. An oil-resistant and drag-chain compatible Controller Cable **3** (see 9 Technical Data) allows the DynamicMold® Inserts to be controlled by the DynamicMold® LinQ **4** industrial computer.

The DynamicMold® LinQ is located outside the machine, it can be connected directly to the mains using the supplied power supply (see 9 Technical Data). The DynamicMold® LinQ can be attached to the outside of the injection molding machine using the backside magnets or it can be installed on a top-hat rail, e.g. in the machine's control cabinet, using the optionally available bracket. Communication with a local network and the devices connected to it (e.g. an injection molding machine) is made possible via the connection sockets on its side. A separate socket is used to connect to the Tablet **5** for browser-based configuration of the system.

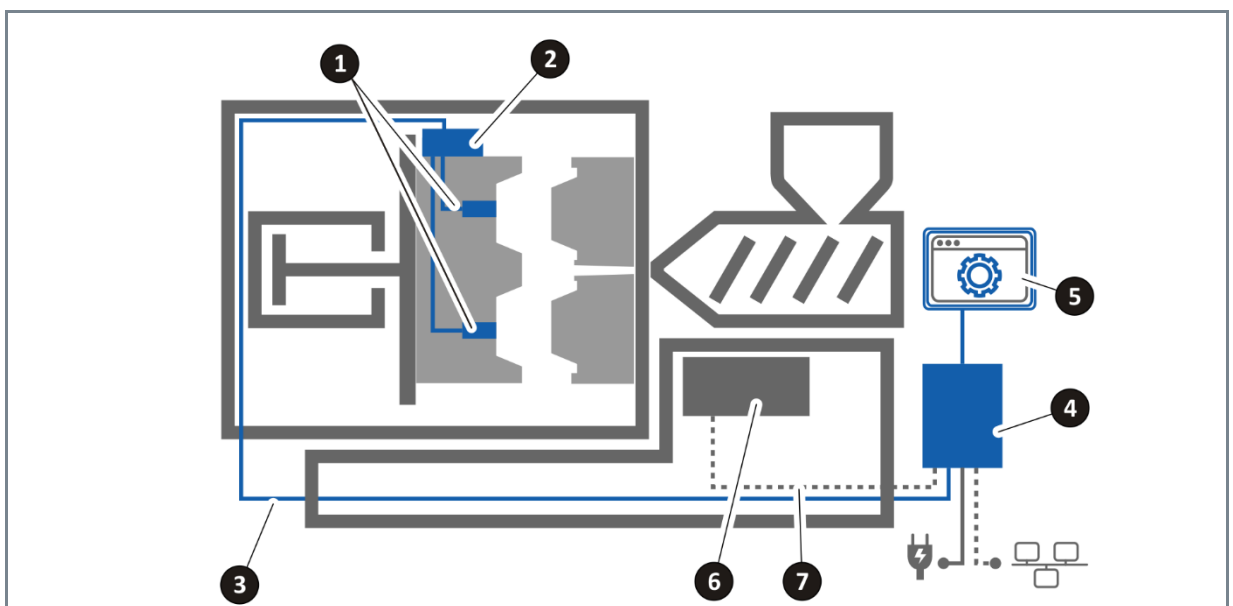

Fig. 1 DM-qode Gen1 system setup

- |                                  |                              |
|----------------------------------|------------------------------|
| <b>1</b> DynamicMold® Insert     | <b>5</b> Tablet              |
| <b>2</b> DynamicMold® Controller | <b>6</b> Maschine Controller |
| <b>3</b> Controller Cable        | <b>7</b> Error Handling      |
| <b>4</b> DynamicMold® LinQ       |                              |

### 3.1 Overview

The DM-qode marking system is composed of a DynamicMold® Insert, a DynamicMold® Controller, a DynamicMold® LinQ including a power supply, a Controller Cable and a Tablet.

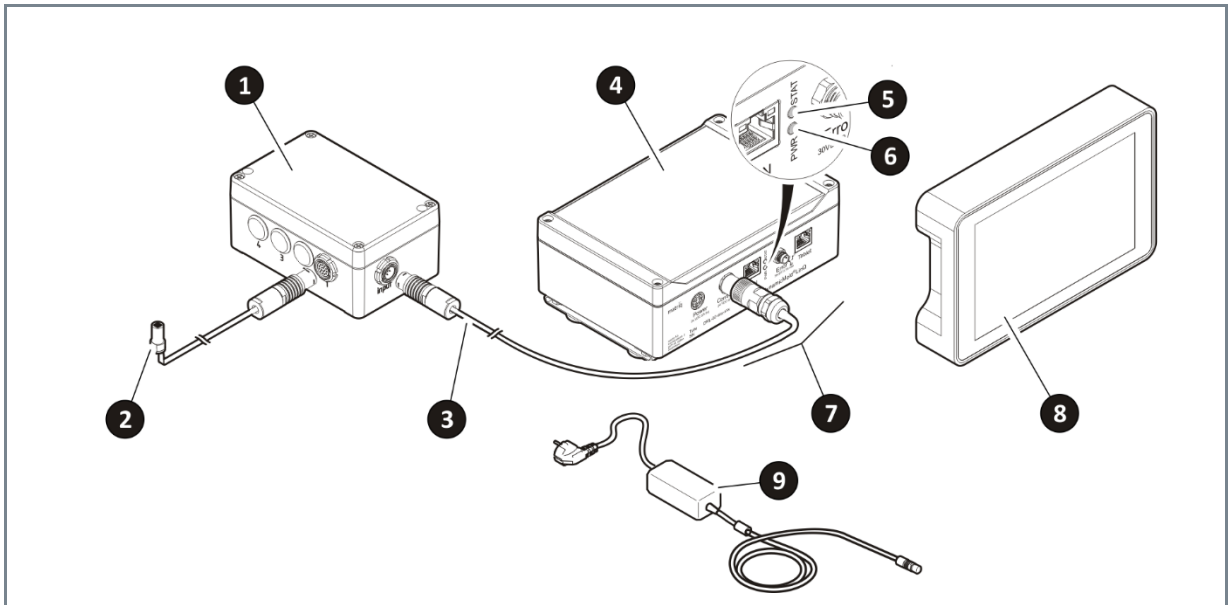

Fig. 2 DM-qode Gen1 System Components

- |  |                                      |
|--|--------------------------------------|
| ① DynamicMold® Controller                                    | ⑤ Status LED                         |
| ② DynamicMold® Insert  | ⑥ Power LED                          |
| ③ Controller Cable (oil-resistant and drag-chain compatible) | ⑦ Connection socket                  |
| ④ DynamicMold® LinQ  | ⑧ Tablet (incl. tablet cable)        |
|  | ⑨ Power supply for DynamicMold® LinQ |

### 3.2 Interfaces

The DynamicMold® Controller ① includes the following interfaces:

- One to four DynamicMold® Insert ports (Channel), depending on the configuration
- Port for connecting to the DynamicMold® LinQ

Interfaces for the DynamicMold® Controller are explained in Chapter 5.4.1.

The DynamicMold® LinQ ④ has the interfaces below:

- 24V DIN 4 Pin «Power»
- One RJ45 socket «LAN» for the network connection
- One RJ45 socket «Tablet» with Power over Ethernet (PoE) to connect the Tablet
- One M8 plug as a potential-free contact for error messages «Error» (see [Fehler! Verweisquelle konnte nicht gefunden werden.](#))
- One M12 5-PIN socket «Controller» for the DynamicMold® Controller

Interfaces for the DynamicMold® LinQ are explained in Chapter 5.6.2.

### 3.3 Status Display

The LEDs on the DynamicMold® LinQ show its current operating status.

#### Power-LED ⑥

- off                      no power
- blue constant            electricity on

#### Status-LED ⑤

- off                      system not yet started
- blue                      system ready, marking inactive
- green                    system ready and marking active
- red                        system error, check error message

### 3.4 Error Contact

The health status (see 3.3) of the system can be transmitted to a third-party system (e.g. a machine controller) via the error contact. This is done using a potential-free contact. The control voltage from the machine is applied to the connection of the error contact. The NO and NC connections (see 3.2) are switched depending on the status of the system.

Status-LED	NC contact	NO contact
<input type="radio"/> off	closed	open
<input checked="" type="radio"/> blue	closed	open
<input checked="" type="radio"/> green	open	closed
<input checked="" type="radio"/> red	closed	open

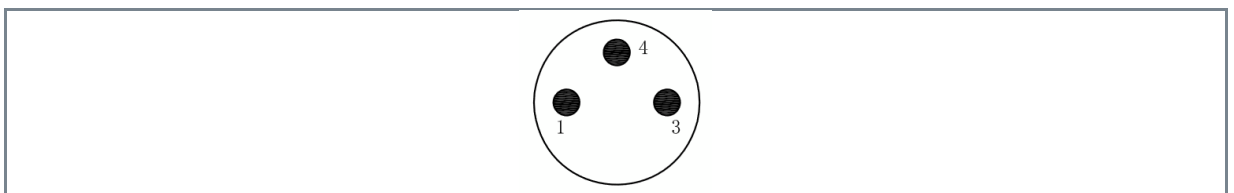

Fig. 3 Front view of the pin allocation

Pin	Signal	Description
1	NO	Normally-open contact
3	NC	Normally-closed contact
4	COM (Common)	Control voltage connection (machine max. 30 VDC, switching current 0.1 A max.)

### 3.5 Symbols



Direct current



Hot surface



CE conformity



Do not unscrew



Do not dispose in household waste



Warning notice

# 4 Transport and Storage

## 4.1 Transport

The components of the DM-qode Gen1 marking system are secured within the cardboard box in accordance with the packaging specifications. All applicable legal requirements for load securing must be followed during transport.

## 4.2 Storage

All system components must be stored in a dry (no condensation) and dark place (away from direct sunlight) inside a clean room. The storage conditions specified in Chapter 9 must be complied with.

# 5 Installation

Follow and comply with all national regulations for electrical installations applicable in the country where the solution is going to be installed. Installation, repair, and maintenance work on the devices may only be carried out by competent personnel (see 2.3).

## 5.1 General Information

- Follow the application-specific requirements provided by matrix
- Also note the information signs found on the devices.
- Never open the devices housings. All component enclosures must always be kept closed.
- Take special care connecting the cables. They and their installation has to comply with applicable rules and regulations.
- Use the connecting cables that come with the marking solution. Do not use cables other than those supplied with it. Do not shorten or lengthen the cables.
- When routing the cables, keep them away from sharp-edged or moving metal parts to prevent damage to them.
- Make sure that all connectors are correctly plugged in and locked in place.

### NOTE



#### POTENTIAL DAMAGE WHEN DISMANTLING THE MOLD!

Because the strain on the DynamicMold® Insert's flat ribbon cable cannot be relieved, it can get damaged or be torn off the insert when the mold is removed.

## 5.2 Wiring Diagram

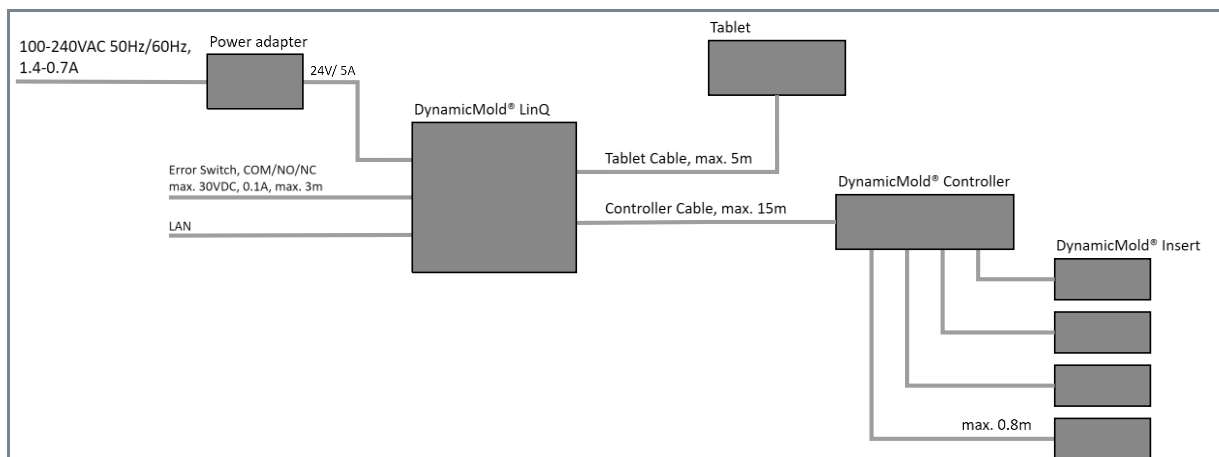

Fig. 4 Wiring diagram for the DM-qode Gen1 marking solution

## 5.3 DynamicMold® Insert

The the DynamicMold® Insert is installed directly in the mold. The required openings and cable ducts are specified for it. The dimensions can be found in the technical drawings (CAD data).

### NOTE



#### DAMAGE FROM A FALLING INSERT!

The DynamicMold® Insert is sensitive to impact and can be damaged if dropped. Be careful when handling the DynamicMold® Insert.

- ▶ Only remove the protective cap and film underneath shortly before installing it into the mold.
- ▶ When installing an insert, hold it with one hand on the cable and the other hand on the housing head or aid for inserting it.

### 5.3.1 Installing a DynamicMold® Insert

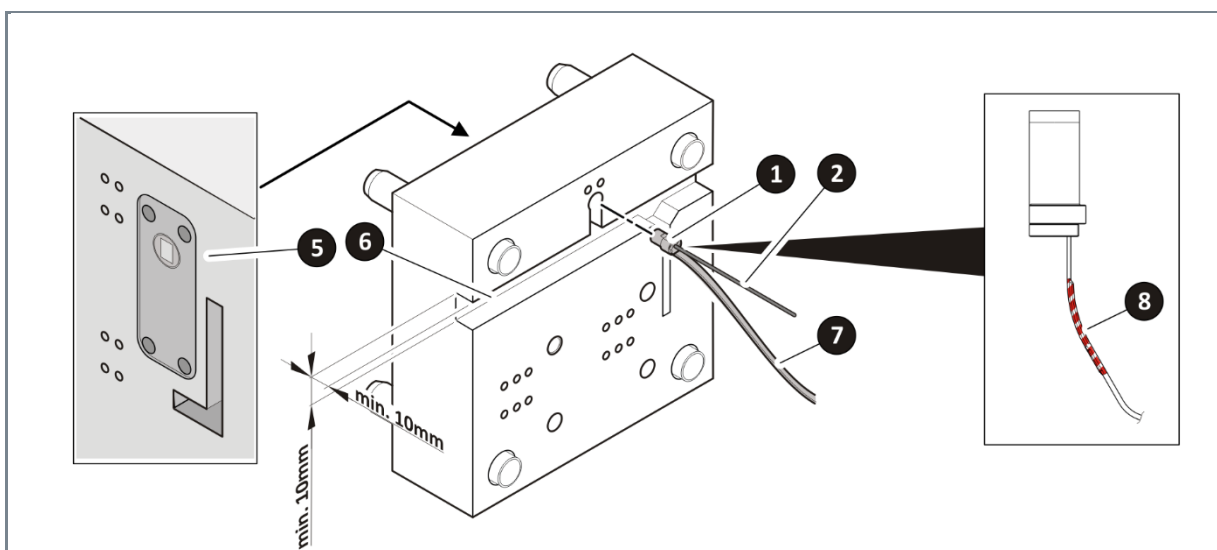

Fig. 5 Installation of a DynamicMold® Insert

- |                       |                                     |
|-----------------------|-------------------------------------|
| ① DynamicMold® Insert | ⑤ Front surface DynamicMold® Insert |
| ② Insertion aid       | ⑥ Cable duct                        |
| ③ Opening             | ⑦ Flat ribbon cable                 |
| ④ Mold                | ⑧ Marked area on Flat ribbon calbe  |

1. Follow the specific requirements for installation. The technical drawings (CAD data) show the options available for DynamicMold® Inserts and either assembling them together with a spacer (not included) or installing them as the base body. Spacer and securing against rotation must be provided by the operating company.
2. Carefully put the DynamicMold® Insert (Fig. 5, ①) through the opening (Fig. 5, ③) of the mold (Fig. 5, ④). Use the insertion aid (Fig. 5, ②).
3. Guide the base body of the DynamicMold® Insert until the surface of the housing head (Fig. 5, ⑤) is lying even with the cavity's edges.
4. Route the cable for the DynamicMold® Insert in the cable duct (Fig. 5, ⑥) as specified in Chapter 5.1.
  - ↳ The DynamicMold® Insert has now been installed and can be connected to the DynamicMold® Controller.

**NOTE****DAMAGE TO THE FLAT RIBBON CABLE!**

The flat ribbon cable is very sensitive and can easily be damaged.

- ▶ The marked area on the flat ribbon cable (Fig. 5, 8) may only be slightly bent and has a minimum bending radius of 20 mm (semi-dynamic). The bending radius of the remaining flat ribbon cable is 5 mm (semi-dynamic). Dynamic bending is not allowed (see 9).
- ▶ The minimum dimensions of the cable duct (Fig. 5, 6) must be 8 mm x 5 mm (width x height). The cable duct should not have any corners or edges that could potentially damage the cable.
- ▶ It is recommended to fix the cable with at least one cable holder to provide additional strain relief for the insert cable.

## 5.4 DynamicMold® Controller

The DynamicMold® Controller is screwed to the mold. The points where it is fastened are specific to the controller's requirements. If the mold temperature exceeds 60°C, spacers must be used for thermal insulation. These are not included in the scope of delivery and must be provided by the operating company. To ensure the specified IP protection rating (see 9), all unused ports must be sealed with the optionally available protective caps.

**NOTE****NEVER OPEN THE ENCLOSURE!**

The housing is mounted diagonally using two screws through designated drill holes. Opening the housing is neither necessary nor permitted.

### 5.4.1 Installing and connecting the DynamicMold® Controller

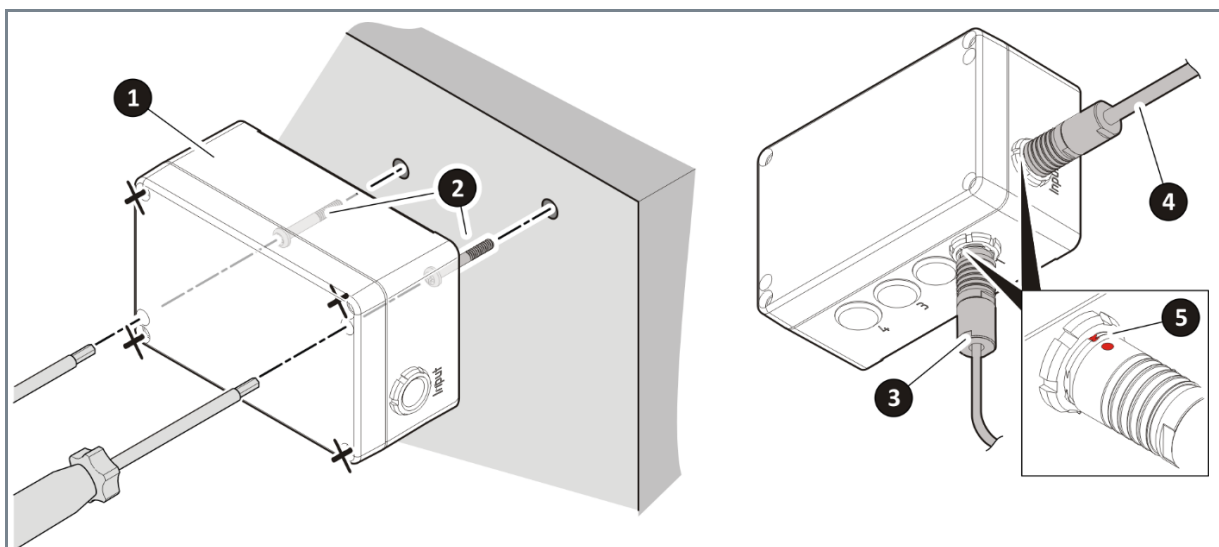

Fig. 6 Installing the DynamicMold® connector and plugging it in

- 1 DynamicMold® Controller enclosure
- 2 16 M4 bolts (included)
- 3 DynamicMold® Insert connector cable
- 4 Controller Cable (oil-resistant and drag chain compatible)
- 5 Markings

**NOTE****ESTABLISH ELECTRICAL CONTACT BETWEEN CONTROLLER AND MOLD!**

In order to guarantee immunity to the electromagnetic environment (see 9), the DynamicMold® Controller must be electrically connected to the mold.

- ▶ A direct connection using metal screws for mounting is sufficient for this purpose.
- ▶ When using spacers for thermal insulation, spacers made of electrically conductive material must be used.

1. Screw the enclosure of the DynamicMold® Controller Fig. 6, ①) to the mold. Use a nut lock to keep the bolts from loosening (Fig. 6, ②). The screw locking method and tightening torques to be used are defined by the operating company.
2. Plug the cable for the DynamicMold® Insert (Fig. 6, ③) into Socket 1 of the DynamicMold® Controller. Use the red marking (Fig. 6, ⑤) to align the plug correctly to the connection socket. When using several DynamicMold® Inserts at once, make sure to assign the Inserts to the sockets that specifically apply to them. Close off any unused connections with the protective caps optionally available.
3. Make sure that as little of the DynamicMold® Insert cable length as possible remains openly accessible, to prevent damage while working on the mold and to reduce the risk of the cable being crushed between the mold plates. If necessary, install a cover plate over the cables and connectors to provide optimal protection. Bundle any excess cable and secure it with a cable tie.
  - ↳ The DynamicMold® Controller has been installed. The mold can now be mounted on the machine.

## 5.5 Controller Cable

The Controller Cable connects the DynamicMold® LinQ to the DynamicMold® Controller. The routing of the cable is specific to the connection to be made and is at the operator's discretion.

### 5.5.1 Installing and Plugging in the Controller Cable

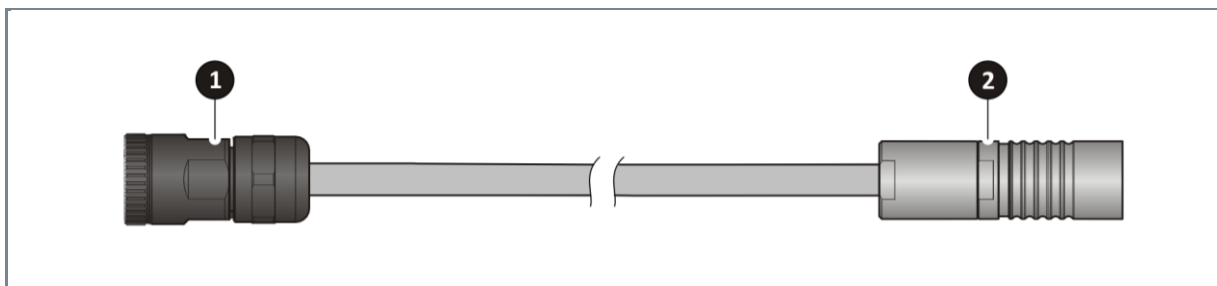

Fig. 7 Plugging in the controller cable

- ① Connector for the DynamicMold® LinQ
- ② Connector for the DynamicMold® Controller

1. Route the cables to avoid sharp-edged or moving metal parts that can mechanically damage the conductor insulation.
2. Make sure the terminal sides for each connecting cable are correct. The black connector (Fig. 7, ①) is for the DynamicMold® LinQ, while the metal-colored connector (Fig. 7, ②) is for the DynamicMold® Controller.
3. Check whether there is enough cabling on both sides for the connection to be made.
4. Plug the controller cable (Fig. 6, ④) into the DynamicMold® Controller's "input" socket (which should have been mounted on the machine beforehand).
  - ↳ The Controller Cable has now been installed.

## 5.6 DynamicMold® LinQ

The DynamicMold® LinQ is installed on a top-hat rail using the optionally available bracket (matriq product number CLP-01-xx), fixed to the outside of the injection molding machine with holding magnets, or placed horizontally. When selecting the installation location, the length of the connecting cables leading to the DynamicMold® Controller (Controller Cable) must be considered.

### NOTE



#### NEVER OPEN THE ENCLOSURE!

The housing is screwed in place using four screws. Opening the housing is neither necessary nor permitted and will invalidate the warranty.

### 5.6.1 Installation Conditions

The DynamicMold® LinQ is intended for proper use indoors and in a protected environment. Permissible ambient conditions are mentioned in Chapter 9.

### CAUTION!



#### DANGER TO PERSONS FROM IMPROPER CABLE LAYING!

- ▶ All cables should be routed so that nobody can trip over or get caught in them.

Check:

- That the installation instructions for the power supply have been considered, in particular
  - The power supply must not be used near water or in a wet environment
  - The power supply must not be used near heat sources
  - Ensure good ventilation to prevent overheating
- That the mains cable plug is easy to reach so that the power supply can be disconnected quickly if necessary
- That the maximum length of the cable to the DynamicMold® Controller is 15 m
- That with a vertical installation, the connection socket points downward
- That with a vertical installation using the holding magnets, no vibrations occur and the holding surface is free of dirt
- That none of the injection molding machine's workflows and operating sequences are disturbed

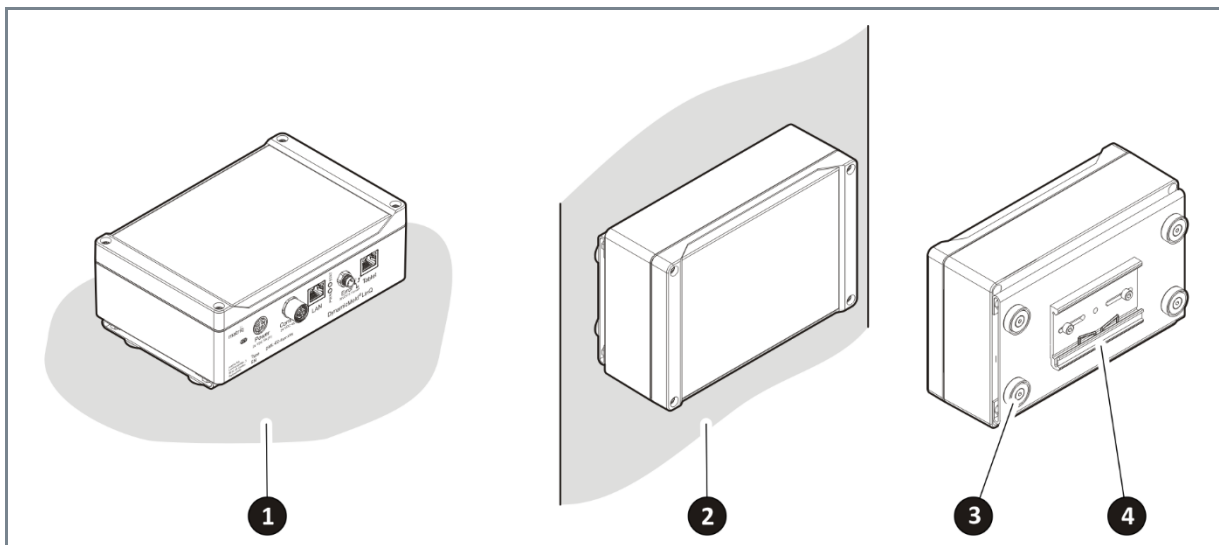

Fig. 8 DynamicMold® LinQ installieren

- ① Horizontal installation
- ② Vertical installation using holding magnets
- ③ Holding magnets
- ④ Top-hat rail bracket (optionally available)

### 5.6.2 Connecting the DynamicMold® LinQ

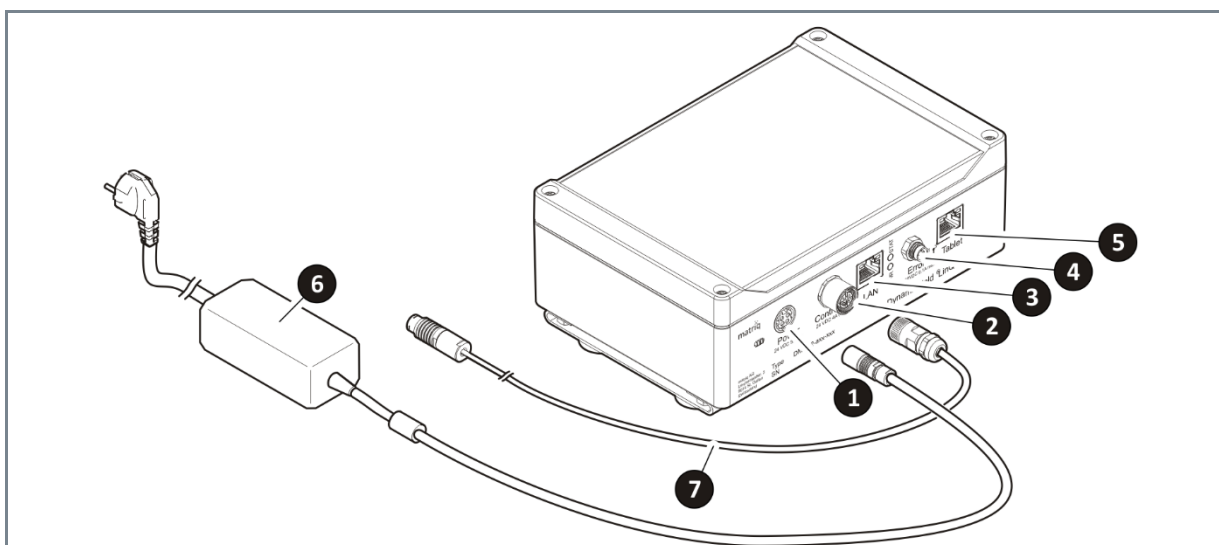

Fig. 9 Cable connections

- ① Power - DIN 4-pin socket (24V power supply)
- ② Controller - M12 5-pin connector (DynamicMold® Controller)
- ③ LAN - RJ45 socket (LAN)
- ④ Error - M8 connector for error contact (optional connection)
- ⑤ Tablet - RJ45 socket with PoE (Tablet)
- ⑥ Power supply with mains cable and plug
- ⑦ Controller Cable

The DynamicMold® LinQ has to be connected to the same power supply as the injection molding machine. Prior to connecting, that the power source meets the specifications of the power supply and is equipped with a protective earthing conductor, an emergency stop switch, a residual current device (RCD), and a fuse rated at max. 13 A. The power supply (Fig. 9, ⑥) supplied with the DynamicMold® LinQ may only be connected to sockets with protective grounding.

1. Connect the electrical plug to the following communication lines for the DynamicMold® LinQ sockets:
  - LAN cable for network connection (IP address + login data required) (Fig. 9, ③)
  - Connecting cable to the DynamicMold® Controller (Fig. 9, ②)
  - Tablet cable for connecting the Tablet (Fig. 9, ⑤)
  - Connecting cable to the injection molding machine (error contact, optional)
2. Connect the 24V connecting cable of the power supply (Fig. 9, ⑥) to the DIN 4-pin socket (Fig. 9, ①).
3. Connect the mains cable of the power supply (Fig. 9, ⑥) with the power grid. Make sure the specifications in **Fehler! Verweisquelle konnte nicht gefunden werden. Fehler! Verweisquelle konnte nicht gefunden werden.** have been considered.
  - ↳ The DynamicMold® LinQ is now correctly connected and starts automatically.
  - ↳ It takes approx. 5 minutes until all system components are ready for operation. If all components are ready and error-free, the status LED lights up in blue (Fig. 2, ⑤).

### 5.6.3 Connecting the Tablet

The Tablet can be fixed to the outside of the injection molding machine using the holding magnets on the back (Fig. 10, ④). Make sure that no vibrations occur and that the holding surface is free of dirt.

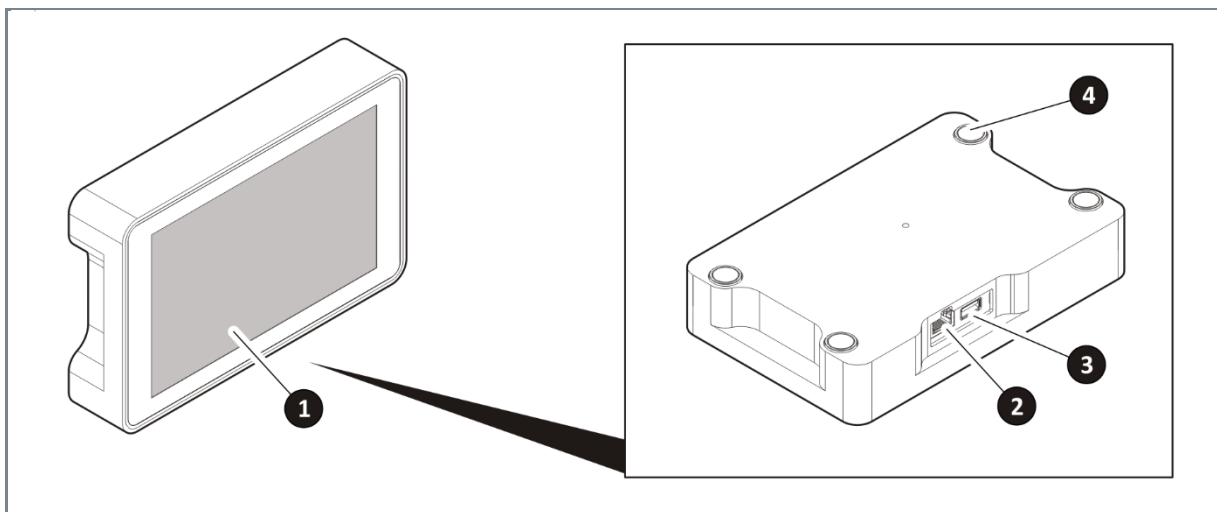

Fig. 10 Tablet connections

- ① Touchscreen
- ② RJ45 socket
- ③ USB port type A
- ④ holding magnets

The Tablet cable is used to connect the Tablet via the RJ45 socket (Fig. 10, ②) to the RJ45 socket with PoE of the DynamicMold® LinQ (Fig. 9, ⑤). If the connection is correct, the LINK / SPEED LEDs on both RJ45 sockets light up. This connection also supplies the Tablet with power.

#### NOTE



#### DAMAGE TO THE TOUCHSCREEN!

- Pointed or sharp objects can damage the plastic surface of the touchscreen.
- Only operate the touchscreen with your finger or a touch pen.

# 6 Operation

## 6.1 Using the Software\*

### 6.1.1 Tablet-Mode

If the Tablet is connected correctly (see [Fehler! Verweisquelle konnte nicht gefunden werden.](#)), the DM-qode Gen1 can be configured via the Tablet. The user interface appears automatically after the Tablet has been connected. No password is required for operation.

### 6.1.2 Network-Mode

In order for the DynamicMold® LinQ to be accessed via the company network, the DynamicMold® LinQ must be connected in accordance with Chapter [5.6.2](#).

- LAN: When the DynamicMold® LinQ is connected to the company network, it is dynamically assigned an IP address via DHCP.
- In addition to the assigned IP address, the DynamicMold® LinQ can be accessed via the host name **matrig-linq-«serial»**. The serial is a 10-digit number and is printed on the DynamicMold® LinQ.

#### Local-Remote-Mode (connectivity via OPC UA)

The OPC UA server is located on port 4840 (standard port for OPC UA). The description of the interface can be found on [matrig.ch/support](http://matrig.ch/support).

\* Full assistance in connecting to the network and using the software is available at [matrig.ch/support](http://matrig.ch/support).

# 7 Maintenance

The DM-qode Gen1 marking system's hardware components require no maintenance. Only matriq is allowed to make changes to the hardware configuration, such as in the number of DynamicMold® Inserts to be connected to the DynamicMold® Controller or any software or firmware updates.

## 7.1 Cleaning the DynamicMold® Insert

### NOTE



#### **DAMAGE CAUSED BY IMPERMISSIBLE CLEANING!**

Cleaning the molds in the injection molding machine with dry ice or solvents can damage the inserts.

- ▶ Remove all DynamicMold® Inserts and the DynamicMold® Controller before cleaning the molds.
- ▶ Never clean the system components in an ultrasonic bath.

If dirt accumulates on the DynamicMold® Inserts, the surface can be rinsed with isopropanol and then cleaned by blowing dry (oil-free compressed air or nitrogen) or by wiping with a lint-free cloth soaked in isopropanol.

## 7.2 Cleaning Tablet

### HINWEIS



#### **DAMAGE TO THE TOUCHSCREEN!**

Cleaning with compressed air, steam jets, high-pressure cleaners, aggressive solvents or abrasive cleaners can damage the touchscreen.

Keep the Tablet clean. Use a damp cleaning cloth with cleaning agent for cleaning. Only use suitable detergents or foaming screen cleaners as cleaning agents.

# 8 Dismantling and Disposal

## 8.1 Dismantling

### CAUTION!



#### **BURN HAZARD!**

The temperature of system parts inside the injection molding machine may rise to elevated levels.

- ▶ Let all system parts cool down before doing any work with them.

### **NOTE**



#### **DAMAGE DUE TO IMPROPER REMOVAL!**

The DynamicMold® Insert can be damaged during removal. Be careful when handling the DynamicMold® Insert.

- ▶ The DynamicMold® Insert must not be knocked out of the mold from the front side (brass, copper or metal rod), as this will damage the surface.
- ▶ The ribbon cable of the DynamicMold® Insert is not strain-relieved. Do not pull the DynamicMold® Insert by the cable. Use the supplied insertion aid for removal.

## 8.2 Disposal

When the product has reached the end of its service life, dispose of it through a specialist company in accordance with statutory regulations.

# 9

## Technical Data

General Ratings			
Environment	For indoor use		
Height	up to 2,000 meters		
Relative humidity	up to 80% at max. 30°C, linearly decreasing by 10% for each 10°C, no condensation		
Storage temperature	0°C - 40°C		
Voltage fluctuation	± 10% of supply voltage		
Overvoltage category	CAT II		
Degree of pollution	2		
Electromagnetic Compatibility:	Parameter	Standard	Test Level
Emission according to EN 61326-1:2020 <sup>1</sup>	Conducted emission:	CISPR 11, CISPR 32	Class B
	Radiated emission:	CISPR 11, CISPR 32	Class A
	Harmonic current:	IEC 61000-3-2	Class A
	Voltage flicker:	IEC 61000-3-3	
Immunity according to SN EN 61326-1:2020	Electrostatic discharges (ESD):	IEC 61000-4-2	CD ± 4 kV CD ± 8 kV
	Radiated RF field:	IEC 61000-4-3	80 – 1000 MHz / 10 V/m 1.4 – 6.0 GHz / 3 V/m <sup>2</sup>
	Electrical fast transients (Burst):	IEC 61000-4-4	Mains ± 2 kV Signal lines ± 1 kV 5 kHz or 100 kHz
	Surge pulses:	IEC 61000-4-5	± 2 kV line to ground ± 1 kV line to line
	Conducted disturbances, RF common mode:	IEC 61000-4-6	3 V (150 kHz – 80 MHz)
	Voltage dips, interruptions, and variations :	IEC 61000-4-11	0% during 1 cycle 40% during 10/12 cycles 70% during 25/30 cycles 0% during 250/300 cycles

<sup>1</sup> The DM-qode Gen1 marking system is considered as a stand-alone unit. Interference emissions exceeding the values listed here may occur when connected to external equipment.

<sup>2</sup> Additional measurement, 1 GHz to 1.4 GHz / 3 V/m

DynamicMold® Insert	
Operating temperature	0°C ... 80°C (mold surface temperature), max. 300°C (melt)
In-cavity pressure	0 bar ... 2000 bar
IP protection	keine
Input	12 VDC $\overline{\text{---}}$ , 11 W max.
Cable bending radius	semi-dynamic (max. 20 times bent): 5 mm, dynamic bending not allowed

DynamicMold® Controller	
Dimension	125 mm x 80 mm x 57 mm
Operating temperature (mold surface temperature)	0°C ... 60°C (up 80°C with extra insulations)
IP protection	IP 65 (SN EN 60529)
Input	24 VDC $\overline{=}$ , 60 W max.
Outputs	4 x max. 12 VDC / 11 W

DynamicMold® LinQ	
Dimension	180 mm x 120 mm x 61 mm
Environment	Do not operate in humid environment or near water
Operating temperature	0°C ... 40°C
IP protection	IP40 (SN EN 60529)
Input	24 VDC, 5 A, DIN 4 Pin (power supply <sup>1</sup> and cable included for 100-240 VAC 50Hz/60 Hz, 1.4 A-0.7 A)
Connections	Network: RJ45 Ethernet (cable not supplied, min. CAT 5) Tablet connection: RJ45 Ethernet with PoE (cable included, min. CAT 5, max. 5 m) DynamicMold® Controller: M12 (cable included) Error switch: M8 male 3PIN (cable not supplied, min. 30 VDC, 0.1 A, max. 3 m)
Connectivity	OPC UA

<sup>1</sup> Further data for the GSM120A24-R7B power supply can be found at <https://meanwell-web.com/>.

Controller Cable	
Operating temperature	0°C - 80°C
Properties	drag chain compatible, oil resistant
Material covering	PUR
Length	7.5 m (max. 15 m)

Tablet	
Dimension	191 mm x 36 mm x 124 mm
Operating temperature	0°C ... 40°C
IP-protection	Front IP65, Steckerabgang IP40 (SN EN 60529)
Input	RJ45 Ethernet mit PoE (IEEE 802.3at, 42.5-57 VDC, 15 W)
Connections	USB 2.0

# 10 Attachment

## 10.1 EC-Declaration of Conformity



the polymer marking solution

Translated from the German original

---

### EC-Declaration of Conformity

---

The manufacturer **matriq AG**  
Lerchenfeldstrasse 3  
9014 St. Gallen  
Switzerland

hereby declares that the following product

Trademark: **DynamicMold®**  
Product: **DM-date**  
Type: **DynamicMold® Insert**  
**DMQ-01-xxxx-xxxx-m**  
└──┬──┘  
12xx / 14xx      xx01 (x:a..z)

**DynamicMold® Controller**  
DMC-02-qxx-axx (DMC-02-q1x-axx / DMC-02-q2x-axx / DMC-02-q4x-axx)  
Compatible module versions according to the latest version of MV\_DM-qode\_Gen1\_RevXX

**DynamicMold® LinQ**  
DML-02-axx-xxx (DML-02-axx-ach / DMC-02-axx-xde / DMC-02-axx-xit)

**Tablet**  
TAB-01-07-xx

**Controller Cable**  
CAB-01-05-xx / CAB-01-07-xx / CAB-01-10-xx / CAB-01-15-xx

complies with all the essential requirements of the directives listed below – including their amendments in force at the time of declaration.

Directives: 2014/35/EU Low Voltage Directive  
2014/30/EU Electromagnetic Compatibility Directive (EMC)  
2011/63/EU RoHS-Directive (use of certain hazardous substances)

This declaration of conformity is issued under the sole responsibility of the manufacturer. For the assessment of compliance, the standards listed below

Standards: EN 61010-1:2010+A1:2019 in conjunction EN 61010-2-010:2020  
EN IEC 61326-1:2020 (Class A)



and the following conformity assessment body were consulted.

Conformity Assessment Body: emv GmbH  
Technoparkstrasse 1  
CH-8005 Zürich  
Kenn-Nr.: STS 0404

Documents: EMVKP11C, 240625\_Safety\_DM-qode\_Gen1, RoHS\_DM-qode\_Gen1\_RevXX

Signed for and on behalf of matriq AG

Place and Date: St. Gallen, 25.03.2025

Signature:  

Name: Klaus Dietrich      André Bernard  
Position: CTO      CEO